

Diaphragm seal with flange connection

Cell-type with extended diaphragm

Model 990.35

WIKA data sheet DS 99.30



for further approvals
see page 7

Applications

- Aggressive, highly viscous, crystallising or hot media
- Chemical and petrochemical process industry
- Thick-walled or insulated pipelines and vessels
- High-pressure applications

Special features

- Intermediate flange (diaphragm seal cell) with extended diaphragm
- Versions for all common standards and nominal widths available
- When special materials are selected, all wetted parts are made of the selected material



Diaphragm seal with flange connection, model 990.35

Description

Diaphragm seals are used for the protection of pressure measuring instruments in applications with difficult media. In diaphragm seal systems, the diaphragm of the diaphragm seal effects the separation of the instrument and the medium. The pressure is transmitted to the measuring instrument via the system fill fluid which is inside the diaphragm seal system.

For the implementation of demanding customer applications, there are a wide variety of designs, materials and system fill fluids available.

For further technical information on diaphragm seals and diaphragm seal systems see IN 00.06 "Application, operating principle, designs".

Together with a blind flange, the model 990.35 diaphragm seal is available for all commonly used standard flanges. Due to the extended diaphragm, the diaphragm seal can be used at thick-walled or insulated locations in pipeline and vessel construction.

Mounting of the diaphragm seal to the measuring instrument may be made via a direct connection, for high temperatures via a cooling element or via a flexible capillary.

For the material selection WIKA offers a variety of solutions, in which the diaphragm seal cell, the extension and the wetted parts can be made of identical or different materials. The diaphragm and the extension can, as an alternative, be coated.

Specifications

Model 990.35	Standard	Option
Level of cleanliness of wetted parts	Oil and grease free per ASTM G93-03 level E (WIKA standard) and ISO 15001 (< 1,000 mg/m ²)	<ul style="list-style-type: none"> ■ Oil and grease free per ASTM G93-03 level D and ISO 15001 (< 220 mg/m²) ■ Oil and grease free per ASTM G93-03 level C and ISO 15001 (< 66 mg/m²)
Origin of wetted parts	International	<ul style="list-style-type: none"> ■ EU ■ CH ■ USA
Extension length	50 mm (1.968 in)	<ul style="list-style-type: none"> ■ 100 mm (3.937 in) ■ 150 mm (5.905 in) ■ 200 mm (7.874 in)
Connection to the measuring instrument	Adapter	-
Type of mounting	Direct mounting	<ul style="list-style-type: none"> ■ Capillary ■ Cooling element
Design per NACE	-	<ul style="list-style-type: none"> ■ MR 0175 ■ MR 0103
Vacuum service (see IN 00.25)	Basic service	<ul style="list-style-type: none"> ■ Premium service ■ Advanced service
Diaphragm seal for mounting to zone 0	-	With flame arrester and PTB certificate
Instrument mounting bracket (only for capillary option)	-	<ul style="list-style-type: none"> ■ Form H per DIN 16281, 100 mm, aluminium, black ■ Form H per DIN 16281, 100 mm, stainless steel ■ Bracket for pipe mounting, for pipe Ø 20 ... 80 mm, steel (see data sheet AC 09.07)

Example: Diaphragm seal model 990.35 with capillary

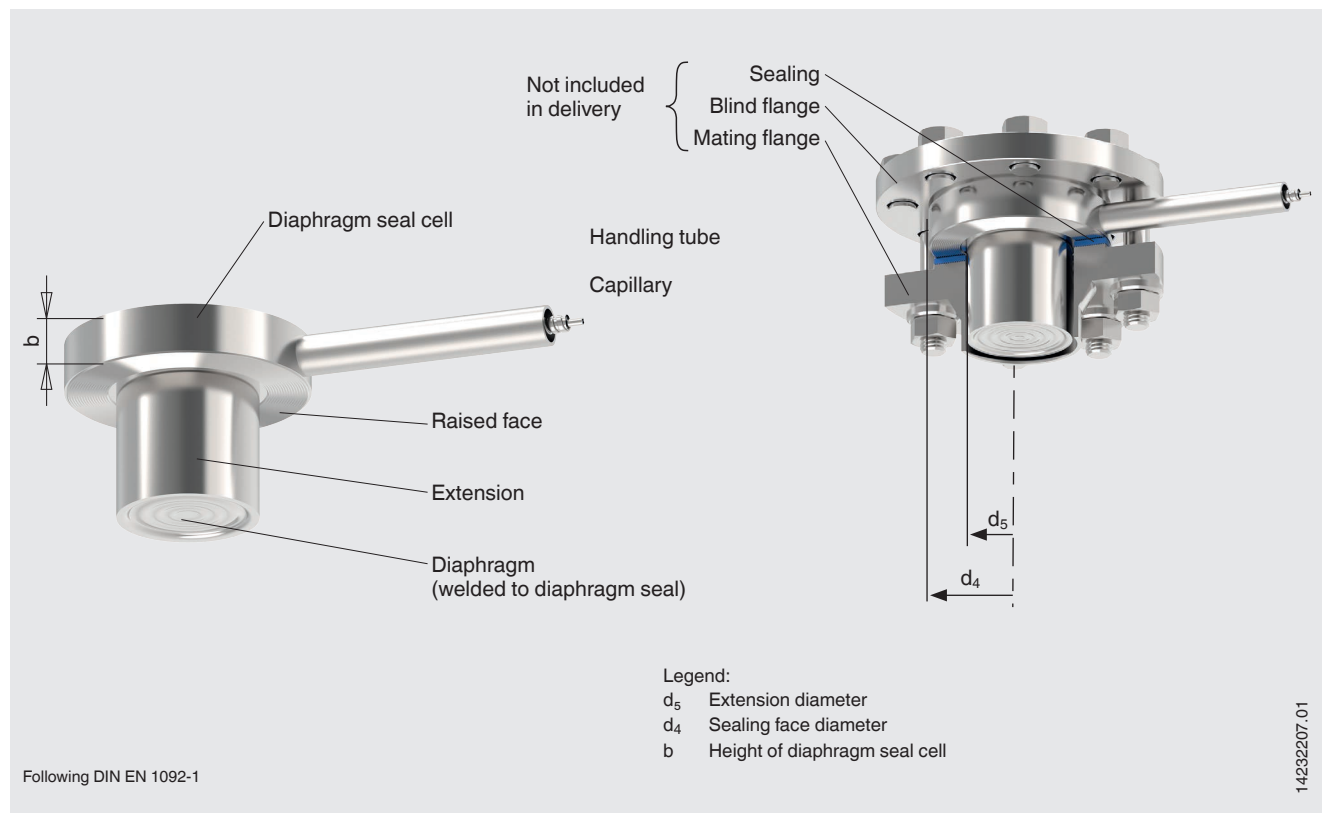

An additional blind flange is required for fixing.

Process connection, flange

Standard	Nominal width	Sealing face	
		Standard	Option
Following DIN EN 1092-1	DN 50	Form B1	<ul style="list-style-type: none"> ■ Form A ■ Form B2 ■ Form C (tongue) ■ Form D (groove) ■ Form E ■ Form F
	DN 80		
	DN 100		
	DN 125		
Following ASME B16.5	2"	RF 125 ... 250 AA	<ul style="list-style-type: none"> ■ RFSF ■ Flat face ■ Small tongue ■ Small male face ■ Small groove ■ Small female face ■ Large tongue ■ Large male face ■ Large groove ■ Large female face ■ RJF groove
	3"		
	4"		
	5"		
Following GOST 33259	DN 25	Type B	<ul style="list-style-type: none"> ■ Type A (flat face) ■ Type C (tongue) ■ Type D (groove) ■ Type E (spigot, male face) ■ Type F (recess, female face)
	DN 40		
	DN 50		
	DN 65		
	DN 80		
	DN 100		
	DN 125		

Further flanges and options on request

Material combinations

Upper body of diaphragm seal	Wetted parts	Maximum permissible process temperature ¹⁾ in °C (°F)
Stainless steel 1.4404 (316L)	Stainless steel 1.4404 / 1.4435 (316L), standard version	400 (752)
	Stainless steel 1.4539 (904L)	
	Stainless steel 1.4541 (321)	
	Stainless steel 1.4571 (316Ti)	
	ECTFE coating	
	PFA (perfluoroalkoxy) coating, FDA	260 (500)
	PFA (perfluoroalkoxy) coating, antistatic	
	Gold plating	400 (752)
	Wikaramic® coating	
	Hastelloy C22 (2.4602)	260 (500)
	Hastelloy C276 (2.4819)	400 (752)
	Inconel 600 (2.4816)	
	Inconel 625 (2.4856)	
	Incoloy 825 (2.4858)	
	Monel 400 (2.4360)	
	Nickel 200 (2.4060, 2.4066)	260 (500)
	Titanium (3.7035)	150 (302)
	Titanium (3.7235)	
Tantalum	300 (572)	
Stainless steel 1.4435 (316L)	Stainless steel 1.4435 (316L)	400 (752)
Stainless steel 1.4539 (904L)	Stainless steel 1.4539 (904L)	
Stainless steel 1.4541 (321)	Stainless steel 1.4541 (321)	
Stainless steel 1.4571 (316Ti)	Stainless steel 1.4571 (316Ti)	
Duplex 2205 (1.4462)	Duplex 2205 (1.4462)	300 (572)
Superduplex (1.4410)	Superduplex (1.4410)	
Hastelloy C22 (2.4602)	Hastelloy C22 (2.4602)	400 (752)
Hastelloy C276 (2.4819)	Hastelloy C276 (2.4819)	
Inconel 600 (2.4816)	Inconel 600 (2.4816)	
Inconel 625 (2.4856)	Inconel 625 (2.4856)	
Incoloy 825 (2.4558)	Incoloy 825 (2.4858)	
Monel 400 (2.4360)	Monel 400 (2.4360)	
Nickel 200 (2.4060, 2.4066)	Nickel 200 (2.4060, 2.4066)	
Titanium 3.7035	Titanium 3.7035	
Titanium 3.7235	Titanium 3.7235	

1) The maximum permissible process temperature is limited by the joining method and by the system fill fluid.

Further material combinations for special process temperatures on request

Flange connection following DIN EN 1092-1, form B1

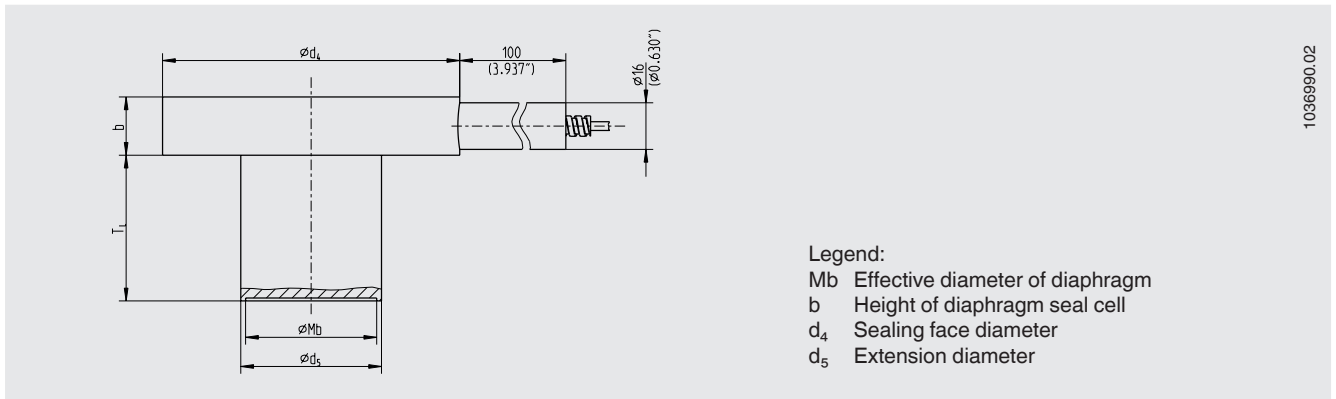

DN	Class	Dimensions in mm (in)			
		Mb	b	d ₄	d ₅
2"	150 ... 600	45 (1.772)	20 (7.787)	102 (4.016)	48.3 (1.902)
3"		72 (2.835)		138 (5.433)	76 (2.992)
4"	150 ... 300	89 (3.504)	20 (7.787)	158 (6.22)	94 (3.701)
5"		124 (4.882)		188 (7.402)	125 (4.921)

Further dimensions and higher nominal pressures on request

Flange connection per ASME B 16.5, RF 125 ... 250 AA

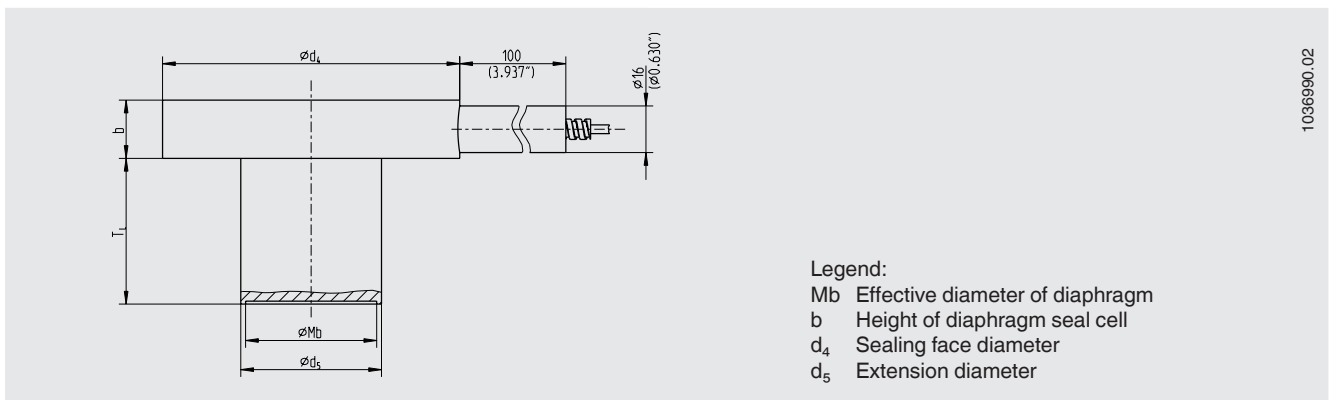

DN	Class	Dimensions in mm (in)			
		Mb	b	d ₄	d ₅
2"	150 ... 600	45 (1.772)	20 (7.787)	100 (3.937)	48.3 (1.902)
3"		72 (2.835)		134 (5.276)	76 (2.992)
4"	150 ... 300	89 (3.504)	20 (7.787)	158 (6.22)	94 (3.701)
5"		124 (4.882)		186 (7.323)	125 (4.921)

Further dimensions and higher nominal pressures on request

Flange connection per GOST 33259, type B

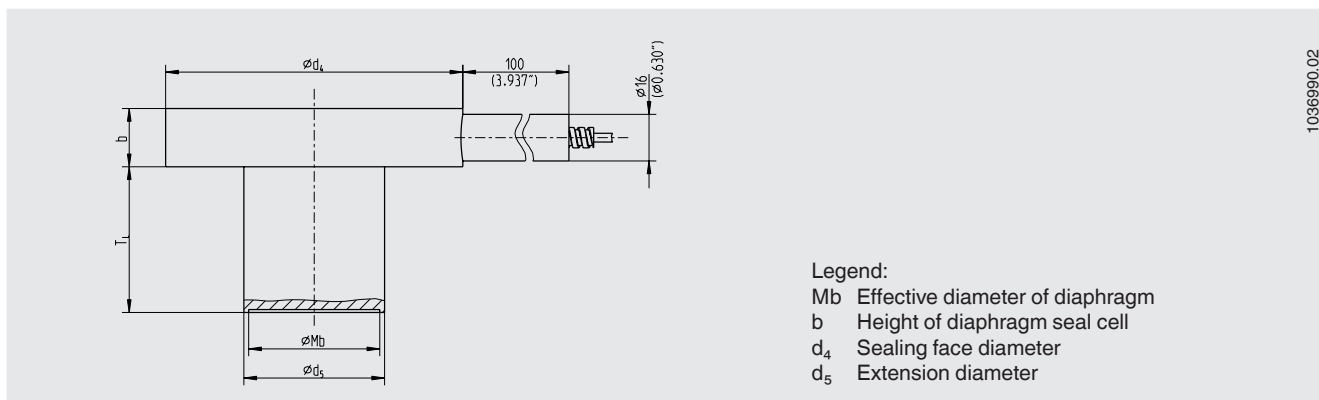

1036990.02

DN	Class	Dimensions in mm (in)			
		Mb	b	d ₄	d ₅
50	10 / 100	40 (1.575)	20 (7.787)	102 (4.016)	44 (1.732)
80		60 (2.362)		133 (5.236)	74 (2.913)
100		72 (2.835)		158 (6.22)	91 (3.583)
125		90 (3.543)		184 (7.244)	111 (4.37)

Further dimensions and higher nominal pressures on request

Approvals

Logo	Description	Country
	EAC (option) Pressure equipment directive	Eurasian Economic Community
-	CRN Safety (e.g. electr. safety, overpressure, ...)	Canada
-	MTSCHS (option) Permission for commissioning	Kazakhstan

Certificates (option)

- 2.2 test report per EN 10204 (e.g. state-of-the-art manufacturing, material proof, indication accuracy for diaphragm seal systems)
- 3.1 inspection certificate per EN 10204 (e.g. material proof for wetted metallic parts, indication accuracy for diaphragm seal systems)

Approvals and certificates, see website

Ordering information

Diaphragm seal:

Diaphragm seal model / Process connection (standard, nominal width, nominal pressure, sealing face, extension length) / Materials (upper body, sealing face, diaphragm) / Level of cleanliness of wetted parts / Origin of wetted parts / Design per NACE / Connection to the measuring instrument / Certificates

Diaphragm seal system:

Diaphragm seal model / Pressure measuring instrument model (per data sheet) / Mounting (direct mounting, cooling element, capillary) / Materials (upper body, sealing face, diaphragm) / Min. and max. process temperature / Min. and max. ambient temperature / Vacuum service / System fill fluid / Certificates / Height difference / Level of cleanliness of wetted parts / Origin of wetted parts / Design per NACE / Diaphragm seal for mounting to zone 0 / Instrument mounting bracket / Process connection (standard, nominal width, nominal pressure, sealing face)

© 02/2005 WIKA Alexander Wiegand SE & Co. KG, all rights reserved.
The specifications given in this document represent the state of engineering at the time of publishing.
We reserve the right to make modifications to the specifications and materials.

