

# Cable thermocouple Model TC40

WIKA data sheet TE 65.40



for further approvals  
see page 2

## Applications

- For direct installation into the process
- Machine building
- Motors
- Bearing
- Pipelines and vessels

## Special features

- Sensor ranges from -40 ... +1,200 °C (-40 ... 2,192 °F)
- For insertion, screw-in with optional process connection
- Cable from PVC, silicone, PTFE or glass fibre
- High mechanical strength
- Explosion-protected versions



Cable thermocouples, model TC40

## Description

Cable thermocouples are particularly suited to those applications in which the metallic probe tip is mounted directly into bored holes (e.g. in machine components) or directly into the process for any application with no chemically aggressive media or abrasion.

For mounting into a thermowell, a spring-loaded compression fitting should be provided, since only this can press the probe tip into the bottom of the thermowell. Otherwise a potentially critical force could be exerted on the measuring tip.







In the standard version the cable probe are manufactured without process connections. Fastening elements such as threaded fittings, union nuts, etc. can also be used.









## Explosion protection (option)

The permissible power,  $P_{max}$ , as well as the permissible ambient temperature, for the respective category can be seen on the EC-type examination certificate, the certificate for hazardous areas or in the operating instructions.

The internal inductance ( $L_i = 1 \mu\text{H/m}$ ) and capacitance ( $C_i = 200 \text{ pF/m}$ ) for cable probes are found on the product label and they should be taken into account when connecting to an intrinsically safe power supply.

## Approvals (explosion protection, further approvals)

Logo	Description	Country
 	<b>EU declaration of conformity</b> <ul style="list-style-type: none"> <li>■ RoHS directive</li> <li>■ ATEX directive (option)</li> </ul> Hazardous areas <ul style="list-style-type: none"> <li>- Ex i Zone 0 gas [II 1G Ex ia IIC T1 ... T6 Ga]</li> <li>Zone 1 mounting to zone 0 gas [II 1/2G Ex ia IIC T1 ... T6 Ga/Gb]</li> <li>Zone 1 gas [II 2G Ex ia IIC T1 ... T6 Gb]</li> <li>Zone 20 dust [II 1D Ex ia IIIC T125 ... T65 °C Da]</li> <li>Zone 21 mounting to zone 20 dust [II 1/2D Ex ia IIIC T125 ... T65 °C Da/Db]</li> <li>Zone 21 dust [II 2D Ex ia IIIC T125 ... T65 °C Db]</li> <li>- Ex n Zone 2 gas [II 3G Ex nA IIC T1 ... T6 Gc X]</li> <li>Zone 22 dust [II 3D Ex tc IIIC T440 ... T80 °C Dc X]</li> </ul>	European Union
 	<b>IECEx (option)</b> (in conjunction with ATEX) Hazardous areas <ul style="list-style-type: none"> <li>- Ex i Zone 0 gas [Ex ia IIC T1 ... T6 Ga]</li> <li>Zone 1 mounting to zone 0 gas [Ex ia IIC T1 ... T6 Ga/Gb]</li> <li>Zone 1 gas [Ex ia IIC T1 ... T6 Gb]</li> <li>Zone 20 dust [Ex ia IIIC T125 ... T65 °C Da]</li> <li>Zone 21 mounting to zone 20 dust [Ex ia IIIC T125 ... T65 °C Da/Db]</li> <li>Zone 21 dust [Ex ia IIIC T125 ... T65 °C Db]</li> </ul>	International
	<b>EAC (option)</b> Hazardous areas <ul style="list-style-type: none"> <li>- Ex i Zone 0 gas [0 Ex ia IIC T3/T4/T5/T6]</li> <li>Zone 1 gas [1 Ex ib IIC T3/T4/T5/T6]</li> <li>Zone 20 dust [DIP A20 Ta 65 °C/Ta 95 °C/Ta 125 °C]</li> <li>Zone 21 dust [DIP A21 Ta 65 °C/Ta 95 °C/Ta 125 °C]</li> <li>- Ex n Zone 2 gas [Ex nA IIC T6 ... T1]</li> <li>Zone 22 dust [DIP A22 Ta 80 ... 440 °C]</li> </ul>	Eurasian Economic Community
	<b>INMETRO (option)</b> Hazardous areas <ul style="list-style-type: none"> <li>- Ex i Zone 0 gas [Ex ia IIC T3 ... T6 Ga]</li> <li>Zone 1 mounting to zone 0 gas [Ex ib IIC T3 ... T6 Ga/Gb]</li> <li>Zone 1 gas [Ex ib IIC T3 ... T6 Gb]</li> <li>Zone 20 dust [Ex ia IIIC T125 ... T65 °C Da]</li> <li>Zone 21 mounting to zone 20 dust [Ex ib IIIC T125 ... T65 °C Da/Db]</li> <li>Zone 21 dust [Ex ib IIIC T125 ... T65 °C Db]</li> </ul>	Brazil

Logo	Description	Country
	<b>NEPSI (option)</b> Hazardous areas - Ex i Zone 0 gas [Ex ia IIC T3 ~ T6] Zone 1 mounting to zone 0 gas [Ex ia/ib IIC T3 ~ T6] Zone 1 gas [Ex ib IIC T3 ~ T6] - Ex n Zone 2 gas [Ex nA IIC T1 ~ T6 Gc]	China
	<b>KCs - KOSHA (option)</b> Hazardous areas - Ex i Zone 0 gas [Ex ia IIC T4 ... T6] Zone 1 gas [Ex ib IIC T4 ... T6]	South Korea
-	<b>PESO (option)</b> Hazardous areas - Ex i Zone 0 gas [Ex ia IIC T1 ... T6 Ga] Zone 1 mounting to zone 0 gas [Ex ib IIC T3 ... T6 Ga/Gb] Zone 1 gas [Ex ib IIC T3 ... T6 Gb]	India
	<b>DNOP - MakNII (option)</b> Hazardous areas - Ex i Zone 0 gas [II 1G Ex ia IIC T3, T4, T5, T6 Ga] Zone 1 gas [II 2G Ex ia IIC T3, T4, T5, T6 Gb] Zone 20 dust [II 1D Ex ia IIIC T65, T95, T125 °C Da] Zone 21 dust [II 2D Ex ib IIIC T125 ... T65 °C Db]	Ukraine
	<b>GOST (option)</b> Metrology, measurement technology	Russia
	<b>KazInMetr (option)</b> Metrology, measurement technology	Kazakhstan
-	<b>MTSCHS (option)</b> Permission for commissioning	Kazakhstan
	<b>BelGIM (option)</b> Metrology, measurement technology	Belarus
	<b>UkrSEPRO (option)</b> Metrology, measurement technology	Ukraine
	<b>Uzstandard (option)</b> Metrology, measurement technology	Uzbekistan

Instruments marked with “ia” may also be used in areas only requiring instruments marked with “ib” or “ic”.  
If an instrument with “ia” marking has been used in an area with requirements in accordance with “ib” or “ic”, it can no longer be operated in areas with requirements in accordance with “ia” afterwards.

Approvals and certificates, see website

## Sensor

### Thermocouple per IEC 60584-1 or ASTM E230

Types K, J, E, N, T (single or dual thermocouple)

#### Sensor types

Type	Operating temperatures of the thermocouple			
	IEC 60584-1		ASTM E230	
	Class 2	Class 1	Standard	Special
K	-40 ... +1,200 °C	-40 ... +1,000 °C	0 ... 1,260 °C	
J	-40 ... +750 °C	-40 ... +750 °C	0 ... 760 °C	
E	-40 ... +900 °C	-40 ... +800 °C	0 ... 870 °C	
N	-40 ... +1,200 °C	-40 ... +1,000 °C	0 ... 1,260 °C	
T	-40 ... +350 °C		0 ... 370 °C	

The table shows the temperature ranges listed in the respective standards, in which the tolerance values (class accuracies) are valid.

The actual operating temperature of the thermometers is limited both by the maximum permissible working temperature and the diameter of the thermocouple and the MI cable, as well as by the maximum permissible working temperature of the thermowell material.

If the temperature to be measured is higher than the permissible temperature at the cable transition, the distance between the cable transition and the critical temperature must be adjusted accordingly by an increased probe length.

Listed models are available both as single or dual thermocouples. The thermocouple will be delivered with an ungrounded measuring point, unless explicitly specified otherwise.

For detailed specifications for thermocouples, see IEC 60584-1 or ASTM E230 and Technical information IN 00.23 at [www.wika.com](http://www.wika.com).

#### Tolerance value

For the tolerance value of thermocouples, a cold junction temperature of 0 °C has been taken as the basis.

## Probe tip designs

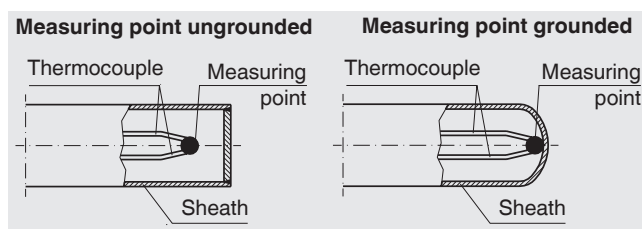

For temperature measurement in a solid body, the diameter of the bore into which the probe should be inserted, should be no more than 1 mm larger than the probe diameter.

Cable thermocouples can be designed in two different ways:

#### ■ Tubular design

The tubular design features a rigid construction to the metal probe tip; therefore tubular designs must not be bent. Within the pipe, the connection cable extends almost to the probe tip. Therefore tubular cable thermocouples can only be used up to the temperature specified for the cables (see operating temperature).

#### Tube diameter:

- 4.0 mm
- 4.5 mm
- 6.0 mm
- 8.0 mm
- Others on request

#### ■ Sheathed design

In sheathed thermocouples the flexible part of the probe is a mineral-insulated cable (sheathed cable). It consists of a stainless steel outer sheath, which contains the insulated internal leads, embedded within a high-density ceramic compound.

Sheathed thermocouples - with the exception of the transition sleeve - may be bent to a radius of 3-times the sheath diameter. Due to this flexibility, the probe can be used in areas that are difficult to access.

#### Sheath diameter:

- 0.5 mm
- 1.0 mm
- 1.5 mm
- 3.0 mm
- 4.5 mm
- 6.0 mm
- 8.0 mm
- Others on request

#### Please note:

The flexibility of the sheathed thermocouple must be considered, especially when the flow rates are relatively high. Designs in which the process connection is not located directly at the cable transition should be considered critical in applications where vibratory or oscillating stresses occur.

## Sheath material

- Ni alloy: alloy 600
  - up to 1,200 °C (air)
  - standard material for applications which require specific corrosion resistance properties under exposure to high temperatures, resistant to induced stress corrosion cracking and pitting in media containing chloride
  - resistant to corrosion caused by aqueous ammonia in all temperatures and concentrations
  - highly resistant to halogens, chlorine, hydrogen chloride
- Stainless steel
  - up to 850 °C (air)
  - good corrosion resistance with aggressive media as well as steam and flue gases in chemical media

Others on request

## Operating temperatures

### ■ Connection cable and single wires

At any point on the connection cable, the maximum temperature that may be attained is that for which the connection cable is specified. The thermocouple itself can potentially withstand higher temperatures.

For the common connection wires the following temperature limits apply:

PVC	-20 ... +100 °C
Silicone	-50 ... +200 °C
PTFE	-50 ... +250 °C
Fibreglass	-50 ... +400 °C

### ■ Transition

The temperature at the transition may be further limited by the use of a potted sealing compound.  
Temperature range of the potting compound: -40 ... +150 °C  
Option: 250 °C  
(other variants on request)

Temperature range of the special low-temperature version:  
-60 ... +120 °C<sup>2)</sup>

<sup>2)</sup> only available with selected approvals

### ■ Connector

With the option of a coupler connector fitted the maximum permissible temperature range is:

Lemosá:	-55 ... +250 °C
Binder:	-40 ... +85 °C

### ■ Working temperature

If the temperature to be measured is higher than the permissible temperature at the cable, connector or transition, the metallic part of the probe must be long enough to be outside of the hot zone. It should be noted that the lowest of the max. operating temperatures for the cable, transition or connector must not be exceeded.

## Transition

The junction between the metal part of the probe and the connecting cable or bare wire should not be immersed within the process and must not be bent. Compression fittings should not be attached to the transition sleeve.

The dimension T describes the length of the transition sleeve.

Criterion	Dimension T <sup>1)</sup> in mm	Ø transition sleeve in mm
Probe Ø = transition sleeve Ø	40	Identical to probe
Ø 2 ... 4.5 mm with crimped transition sleeve	45	6
Ø 6 mm with crimped transition sleeve	45	7
Ø 8 mm with crimped transition sleeve	45	10

For operating temperatures < -40 °C the transition sleeve is designed as follows:

Criterion	Dimension T in mm	Ø transition sleeve in mm
Probe Ø = transition sleeve Ø	60	Identical to probe
Ø 2 ... 4.5 mm with crimped transition sleeve	60	8
Ø 6 mm with crimped transition sleeve	60	8
Ø 8 mm with crimped transition sleeve	60	10

<sup>1)</sup> The transition sleeve is generally 60 mm long for 2 x 4-wire sensor connection method.

### Connecting cable

There are various insulating materials available to suit any particular environmental conditions.  
The cable ends can be prepared ready for connection, or as an option, can be fitted with connectors.

### Connection cable (standard)

- Thermocouple, adapted to the sensor
- Cross-section: min. 0.22 mm<sup>2</sup>
- Number of thermocouples:  
dependent on the connection method
- Insulation material: PVC, silicone, PTFE or fibreglass
- Screen (option):  
Recommendation for connection to transmitter

## IP ingress protection

Cable thermocouples can be delivered with up to IP65 (dependent on cable sheath material and number of wires). With a special design, IP67 is also possible on request. Connection leads with a glass-fibre sheath cannot be combined with an explosion-proof version.

## Designs

Cable thermocouples are classified into the following variants, depending on the nature of their electrical connections:

- With single wires
- With connection cable
- With connector
- With bare connecting wires

### Connection with single wires

Cable length 150 mm, other lengths on request, thermo wire  $\varnothing$  0.5 mm, compensating cable type according to the sensor type, PTFE-insulated, number of cable end pairs according to the number of sensors, bare wire ends other versions on request

### With connection cable

Cable and probe are permanently connected to each other. Cable length to customer specification  
Compensating cable, leads 0.22 mm<sup>2</sup>, compensating cable type depending on the sensor type, number of wires according to number of sensors, bare wire ends

### With connector fitted to connection cable

The optional coupler connector is fitted to a flexible connection cable.

### Designs with bare connecting wires

The internal leads of the mineral-insulated cable protrude.  
L = 20 mm (standard)

The length of the bare connecting wires can be matched to customer requirements. These bare internal leads are made from solid wire, and so are not suitable to be run over long distances.

### Design with connector fitted directly to the probe

These designs are based on the design with bare connecting wires. The connector is fitted directly to the metallic probe.

The dimension A describes the insertion length into the process. The dimension W describes the length of the connecting wire. L is the length of the single wires. The dimension T describes the transition sleeve (if present). T is always a constituent of the length W or L (see table on page 5).

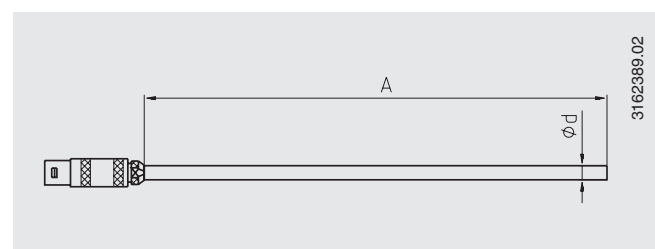
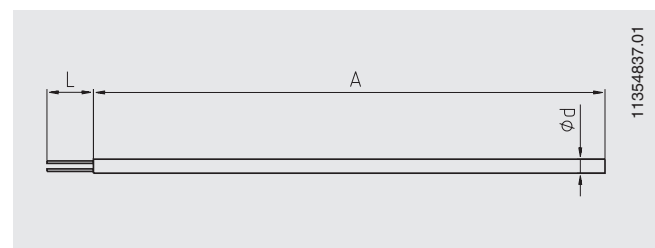
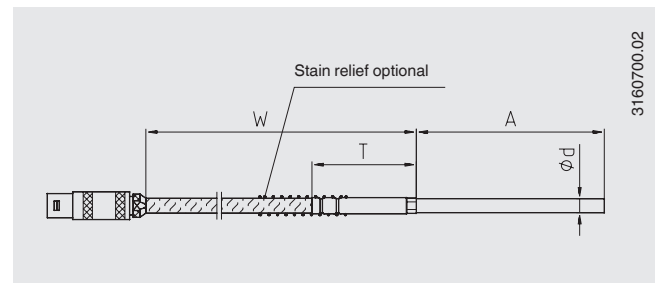
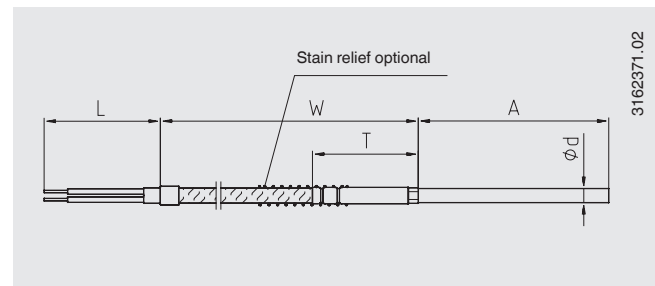
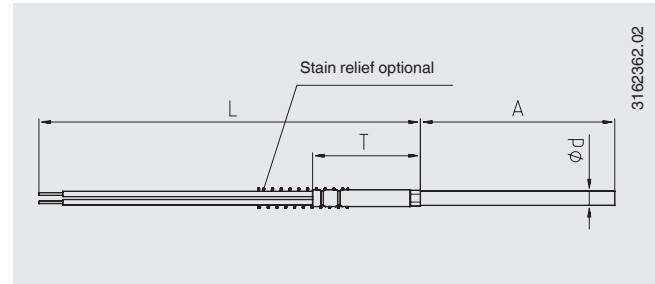

## Process connections for straight probes

The cable thermocouples can be fitted with an optional process connection. The dimension A describes the insertion length into the process.

To minimise heat dissipation errors via the threaded connection, the insertion length, A, should be at least 25 mm long. The position of the threaded connection is specified by the dimension X and is not dependent on the connection type.

### Fixed threaded connections/threads

used to mount the probe into a threaded coupling with a female thread.

Insertion length A: in accordance with customer specification  
Material: stainless steel, others on request

The probe must be rotated in order to screw it into the process. Therefore, this design must first be mounted mechanically and it can then be electrically connected.

### Compression fitting

allows simple adjustment to the required insertion length at the installation point.

Since the compression fitting is adjustable on the probe, the dimensions A and X are stated as the values for the delivered item. The length of the compression fitting determines the smallest possible length, X, of approx. 40 mm.

Material: stainless steel

Ferrule material: stainless steel or PTFE

Stainless steel ferrules can be adjusted once; once they have been unscrewed, sliding along the sheath is no longer possible.

- Max. temperature at process connection 500 °C
- Max. pressure load 40 bar

PTFE ferrules can be adjusted several times, after unscrewing, repeated sliding along the sheath is still possible.

- Max. temperature at process connection 150 °C
- For use without pressure

For sheathed thermocouples with a  $\varnothing$  of 2 mm, only PTFE ferrules are approved.

### Please note:

- For parallel threads (e.g. G 1/2) the dimensioning always refers to the sealing collar of the threaded connection nearest the process
- For tapered threads (e.g. NPT) the measurement plane is located approx. in the centre of the thread

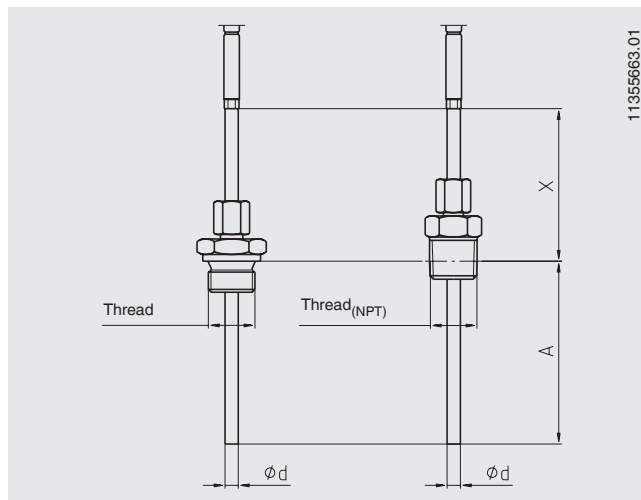
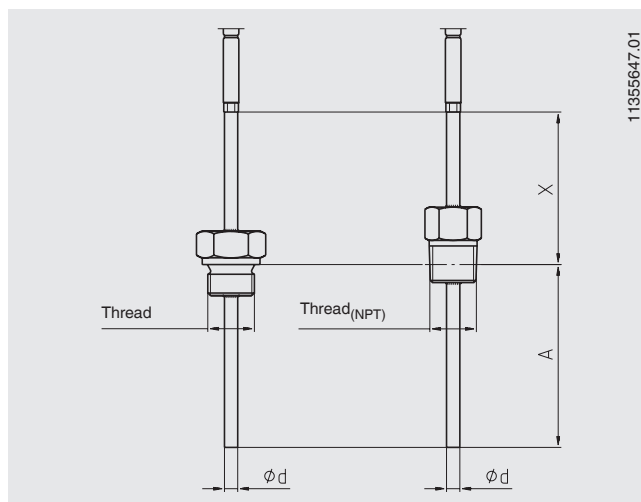

### Spring-loaded compression fitting

allows easy adjustment to the desired insertion length at the mounting point, while at the same time maintaining the spring pre-tension

Since the compression fitting is adjustable on the probe, the dimensions A and X are stated as the values for the delivered item. The length of the compression fitting determines the smallest possible length, X, of approx. 80 mm.

Material: stainless steel

Ferrule material: stainless steel

Stainless steel ferrules can be adjusted once; once they have been unscrewed, sliding along the sheath is no longer possible.

Max. temperature at process connection 500 °C

A pressure load on the compression fitting is not intended.

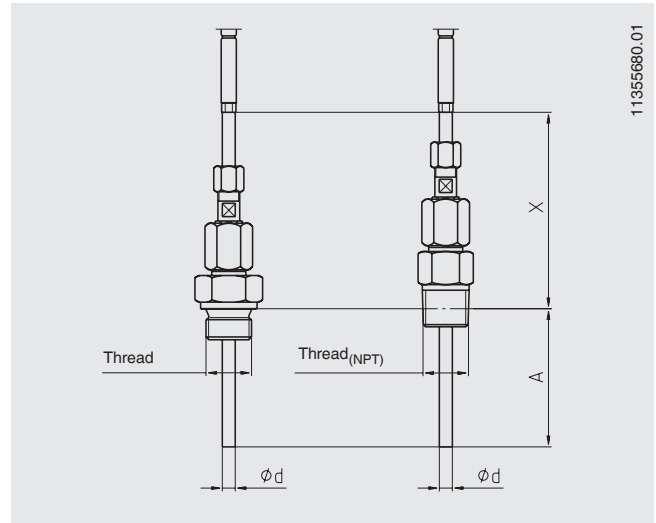

### Spring-loaded compression fitting, can work with pressures up to max. 8 bar

allows easy adjustment to the desired insertion length at the mounting point, while at the same time maintaining the spring pre-tension, intended for use with hydraulic oil

Since the compression fitting is adjustable on the probe, the dimensions A and X are stated as the values for the delivered item. The length of the compression fitting determines the smallest possible length, X, of approx. 80 mm.

Material: stainless steel

Ferrule material: stainless steel

Stainless steel ferrules can be adjusted once; once they have been unscrewed, sliding along the sheath is no longer possible.

Permissible temperature at process connection -30 ... +100 °C

A pressure load on the spring-loaded compression fitting is permissible up to a max. 8 bar.

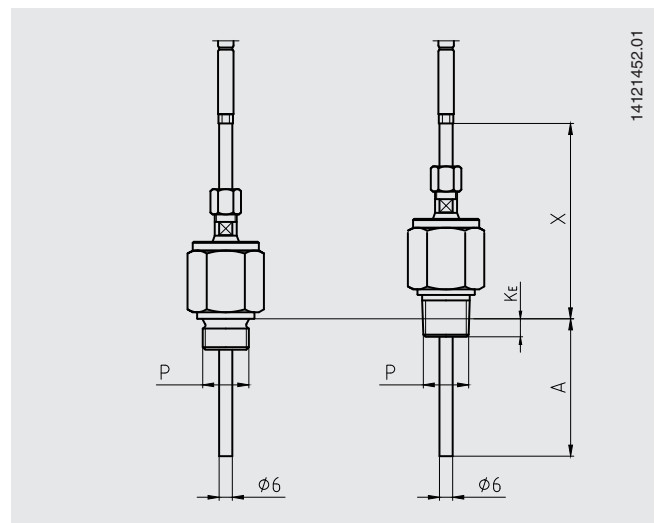



### Union nut

used to mount the probe into a threaded coupling with a male thread.

The probe and threads rotate against each other, so the order in which the mechanical and electrical installation is made is not important.

This option is not advisable for NPT threads.

Insertion length A: in accordance with customer specification  
Material: stainless steel, others on request

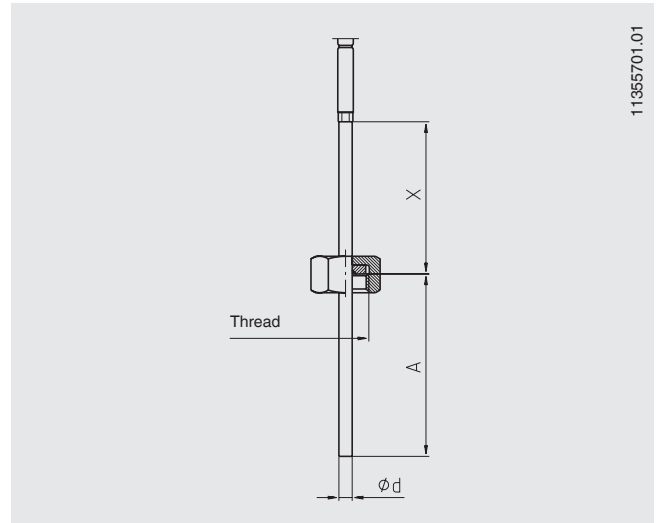

### Male nut

used to mount the probe into a threaded coupling with a female thread.

The probe and threads rotate against each other, so the order in which the mechanical and electrical installation is made is not important.

This option is not advisable for NPT threads.

Insertion length A: in accordance with customer specification  
Material: stainless steel, others on request

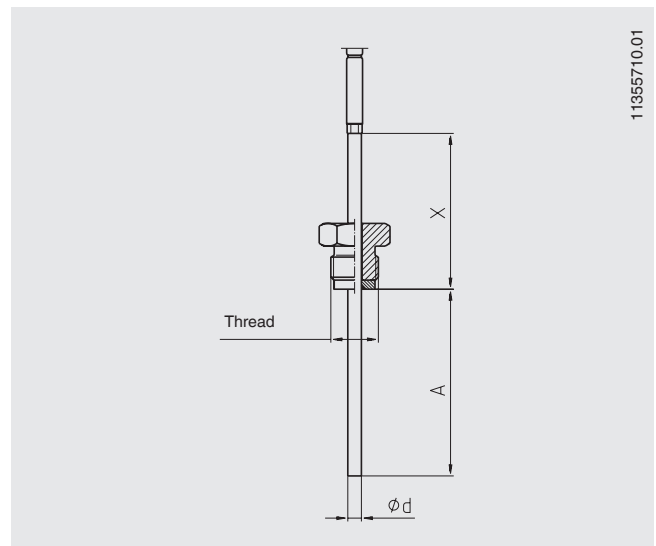

# Angled probes

Cable thermocouples made from sheathed cable can be delivered in a pre-formed shape. In this case, the position of the bend is defined by a further dimension.

The dimension X describes the distance of the bend from the lower edge of the transition sleeve.

The dimension A is always the insertion length of the probe, and thus the area which is built in to the process.

If a threaded connection is used on the bent probe, then the dimension Y describes the distance from the centre of the bend to the measurement plane of the threaded connection.

Using a fixed threaded connection is not recommended, as the angled probe would need to be screwed into the process with a wide sweeping movement.

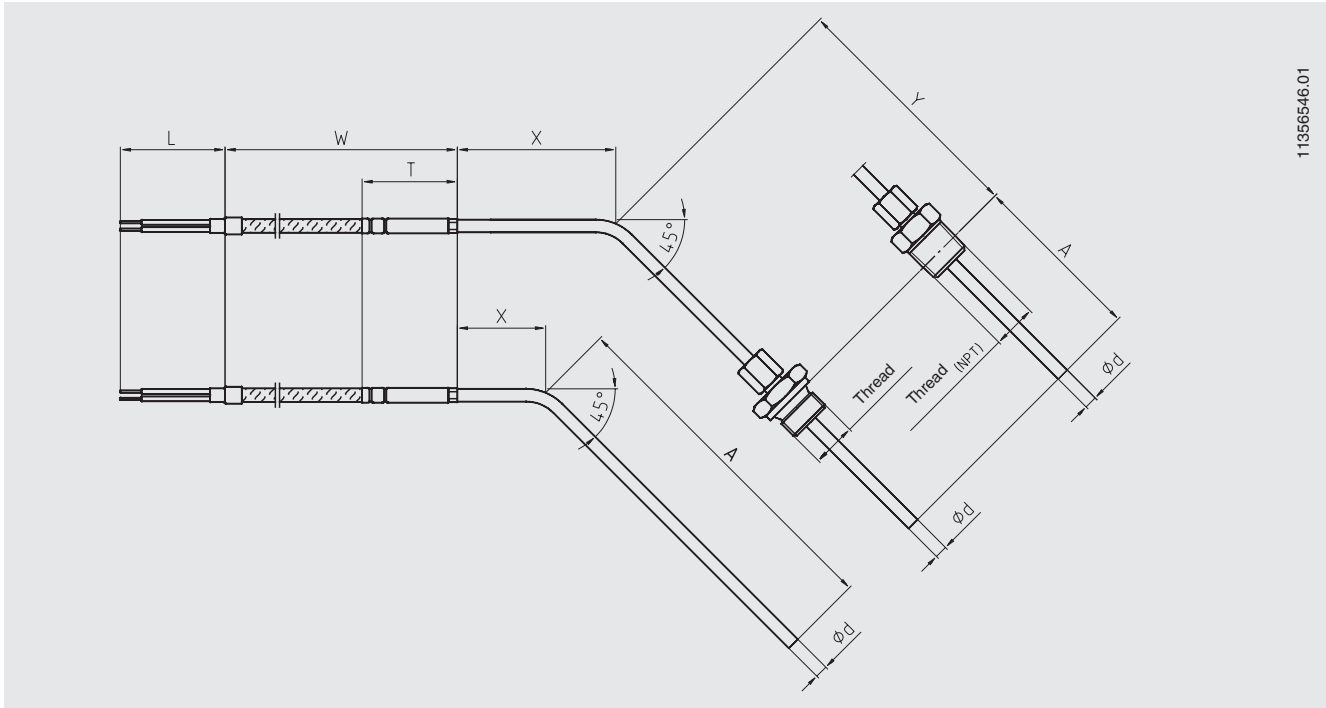
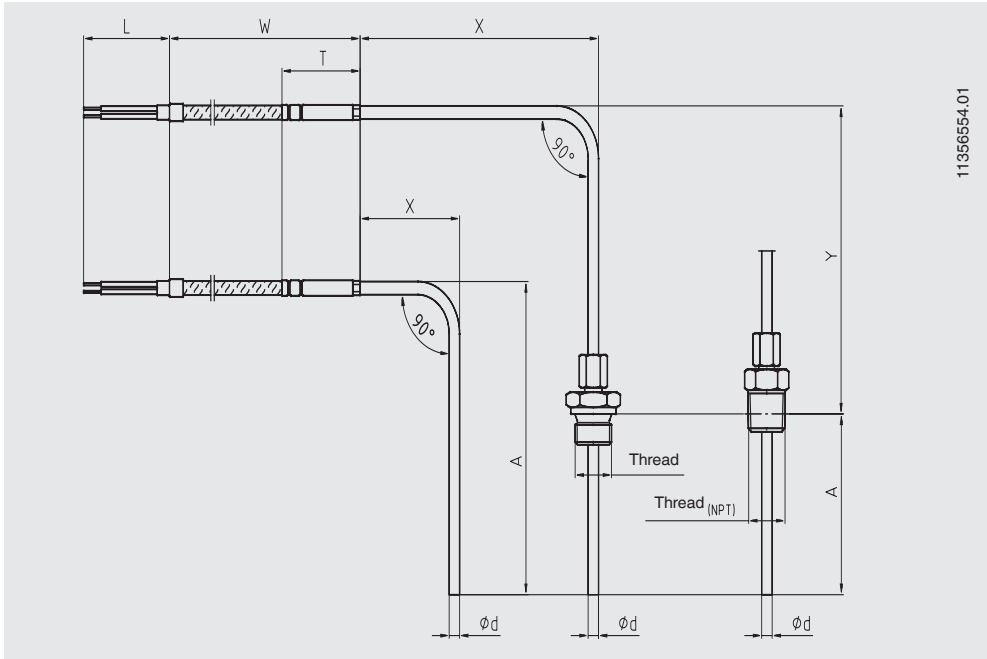

## Connector (option)

Cable thermocouples can be supplied with connectors fitted.  
The following options are available:

### ■ Screw-in-plug, Binder (male)

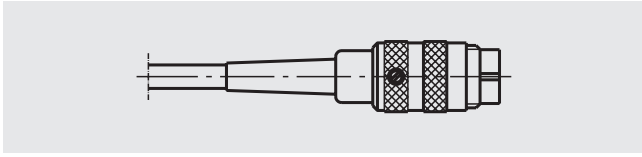

### ■ Screw-in-plug, Binder (female)

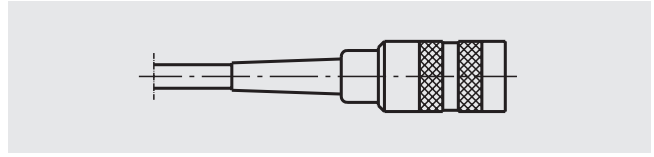

### ■ Lemosa connector size 1 S (male)

### ■ Lemosa connector size 2 S (male)

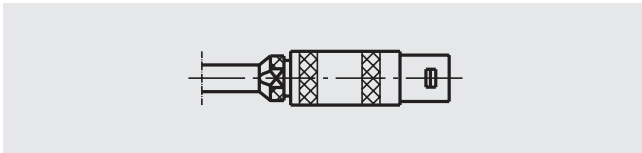

### ■ Lemosa free socket size 1 S (female)

### ■ Lemosa free socket size 2 S (female)

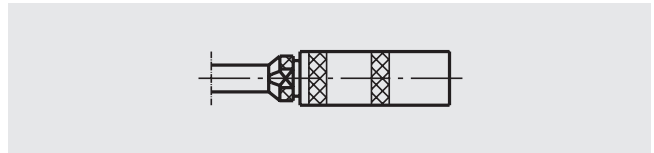

### ■ Standard thermo connector 2-pin (male)

### ■ Miniature thermo connector 2-pin (male)

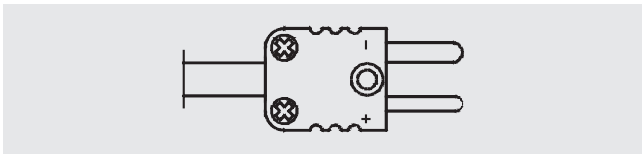

### ■ Standard thermo socket 2-pin (female)

### ■ Miniature thermo socket 2-pin (female)

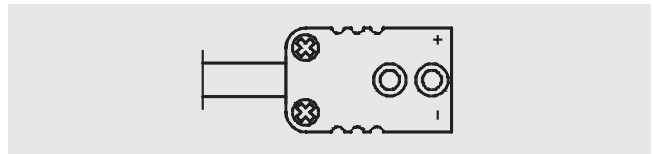

### ■ Spade lugs

(not suitable for versions with bare connecting wires)

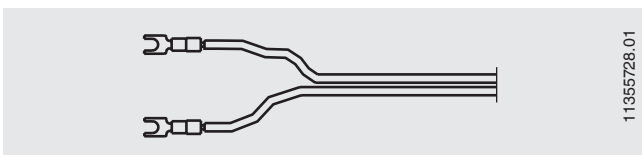

Other plug variants (sizes) on request.

## Further options

### Stain relief

A stain relief (spring or shrink hose) is used to protect the transition point from rigid probe to flexible connecting cable. This should always be used when a relative movement between the cable and the thermometer mounting is expected.

For designs to Ex n the use of stain relief is obligatory.

The standard length of the stain relief spring is 60 mm.

### Transition sleeve with the same diameter as the probe

Optionally, a transition sleeve can also be selected that has the same diameter as the metal probe. This makes it possible to slide on cable glands or compression fittings from both ends of the probe. The transition is hardly visible.

The operating limits of the transition sleeve do not change, however, i.e. they must still remain outside the process and should not be loaded with a compression fitting.

# Electrical connection

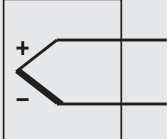
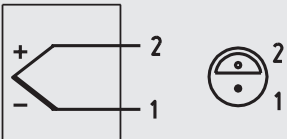
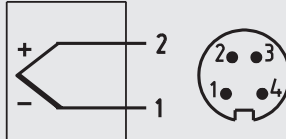
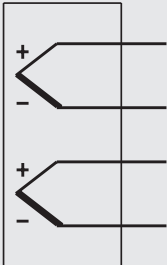
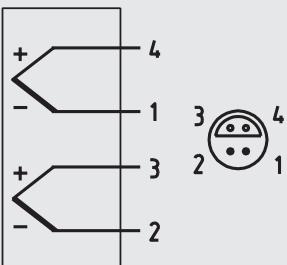
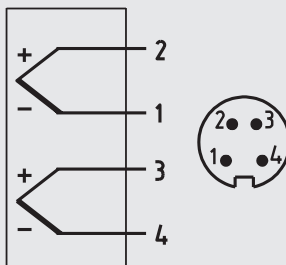
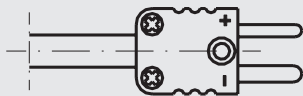
Cable	Lemosa connector, male at the cable	Binder connector Series 680, Series 423 (shielded), male at the cable (screw-in-plug)
<p>Marking of wire ends see table</p>	<p>max. permissible temperature range: -55 ... +250 °C</p>	<p>max. permissible temperature range: -40 ... +85 °C</p>
<p>3171966.01</p>	<p>3374896.01</p>	<p>3374900.02</p>
<p><b>Single thermocouple</b></p> 		
<p><b>Dual thermocouple</b></p> 		
<p><b>Thermo connector</b></p>	<p>Positive and negative terminal are marked. Two thermo connectors are used with dual thermocouples.</p>	

Other coupler connectors and pin assignments on request.

## Colour code of cable

Sensor type	Standard	Positive	Negative
K	IEC 60584	Green	White
J	IEC 60584	Black	White
E	IEC 60584	Violet	White
T	IEC 60584	Brown	White
N	IEC 60584	Pink	White

For further information on colour codes see Technical information IN 00.23 at [www.wika.com](http://www.wika.com).

## Certificates (option)

Certification type	Measurement accuracy	Material certificate
2.2 test report	x	x
3.1 inspection certificate	x	x
DKD/DAkkS calibration certificate	x	-

The different certifications can be combined with each other.

## Ordering information

Model / Explosion protection / Sensor version / Threaded connection version / Thread size / Materials / Sensor diameter / Measuring element / Connection method / Temperature range / Connection cable, jacket / Lead ends version / Certificates / Options

© 10/2008 WIKA Alexander Wiegand SE & Co. KG, all rights reserved.  
The specifications given in this document represent the state of engineering at the time of publishing.  
We reserve the right to make modifications to the specifications and materials.

