

Pressure Gauge Syphons

Model 910.15

Accessories, Mechanical

Service intended

Pressure gauge syphons are intended to protect the pressure gauge from the effect of hot pressure media such as steam and also to reduce the effect of rapid pressure surges. Condensate of the pressure medium that is collected inside the coiled or U-shaped portion of the syphon prevents direct contact. When first installed the syphon should be filled with water or any other suitable separating liquid.

Design

Syphons can be supplied in designs to comply with DIN 16 282 and other industrial standards.

Forms

U-form to fit horizontal pressure tap
 Trumpet form to fit vertical pressure tap

Standard features

Pressure connection

See table overleaf

Materials



Carbon steel and
 Stainless steel 1.4571

Optional extras

- Thread other than G
- Special steel alloy
- Stainless steel 1.4571 degreased for oxygen
- With material test certificate 3.1 B / 3.1 A

1. Design per DIN 16 282

With welding connection on the process side

Design	Max. working temperature °C	Max. working pressure [bar]	Material	Product no.
U-form  Gauge side: LH / RH union G 1/2				
Form B	120 300 400	100 80 63	St 35.8-l. 1.4571	90 91190 13 23270
Trumpet form  Gauge side: LH / RH union G 1/2				
Form D	120 300 400	100 80 63	St 35.8-l. with 3.1 B 1.4571 with 3.1 B	90 91211 16 14940 14 40497 16 14924



Carbon steel syphons DIN 16 282
 U-form, Form B Trumpet form, Form D

Dimensions [mm]

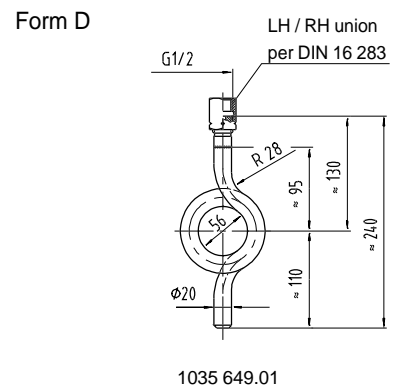
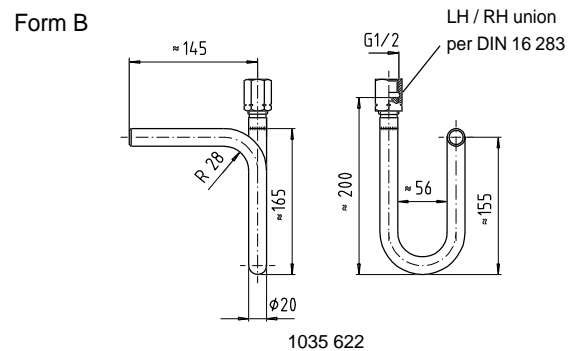

2. Industrial standard designs

Dimensions [mm]

With screwed connection on the process side

U-form

Design U-form	Max. working temperature °C	Max. working pressure [bar]	Material	Product no.
Gauge side: LH / RH union G 1/2				
Entry: G 1/2 B	120	100	St 35.8-l.	90 91181
	300	80	1.4571	90 91220
400	63			
Trumpet form				
Gauge side: LH / RH union G 1/2				
Entry: G 1/2 B	120	100	St 35.8-l.	90 91203
	300	80	1.4571	90 91238
	400	63		

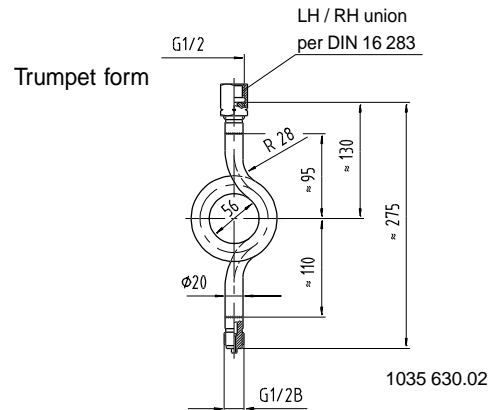
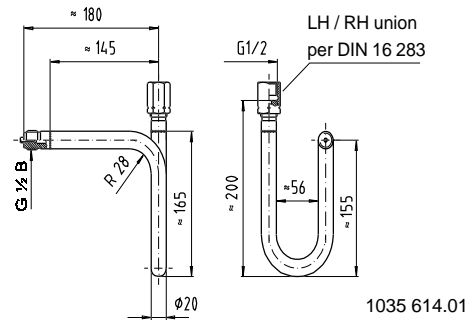

Design	Connection thread G	Max. working pressure [bar]	Material	Dimensions [mm]						Product no.
				D	h	h ₁	l	r	s	
U-form Both sides male pipe thread	R 1/4 -2999 ²⁾	25	St 35.8-l.	-	170	130	225	26.55	13	90 90649
	R 1/2 -2999 ²⁾	25	St 35.8-l.	-	170	130	225	22.5	17	90 90657
Entry: G 1/2 B Gauge side: LH / RH union G 1/2	R 1/2 -2999 ²⁾	25	St 35.8-l.	-	170	130	225	22.5	17	90 90665
	G 1/2 B ³⁾	160	St 33	-	170	130	225	22.5	20	90 90673
Entry: butt welding ¹⁾ Gauge side: LH / RH union G 1/2	G 1/2 B	25	St 35.8-l.	-	170	130	-	22.5	-	90 90681
Trumped form Both sides male pipe thread	R 1/4 -2999 ²⁾	25	St 35.8-l.	64	240	120	-	-	13	90 90592
	R 1/2 -2999 ²⁾	25	St 35.8-l.	56	240	120	-	-	17	90 90606
Entry: G 1/2 B Gauge side: LH / RH union G 1/2	R 1/2 -2999 ²⁾	25	St 35.8-l.	56	250	120	-	-	17	90 90614
	G 1/2 B ³⁾	160	St 33	56	275	120	-	-	20	90 90622

1) Chamfered for root welding.
2) Thread machined on pipe.

3) With butt welding nozzle

Dimensions

U-form

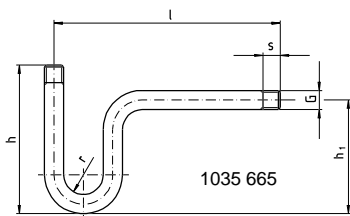

Trumpet form

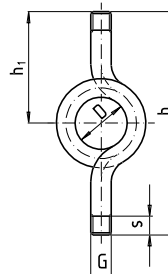

1035 665

1035 673

Ordering information

To order the described products the 7-digit product number is sufficient / Optional extras required

Specifications and dimensions given in this leaflet represent the state of engineering at the time of printing. Modifications may take place and materials specified may be replaced by others without prior notice.



WIKA Alexander Wiegand GmbH & Co. KG
Alexander-Wiegand-Straße · 63911 Klingenberg
Tel.: (0 93 72) 132-0 · Fax: (0 93 72) 132-406
http://www.wika.de · E-mail: info@wika.de