

SUPERFLOW Flowmeter

KF500 series of turbine flowmeter

instruction manual



Catalog

1.	brief introduction of turbine flowmeter	P01
2.	Turbine flow sensor	P01
1.1	Flow range	P01
1.2	Flange connection dimension	P02
1.3	size of thread screw	P03
1.4	Hoop - type connection size	P04
3	Selection	P05
4	Installation	P06
4.1	the installation site	P06
4.2	Installation direction and position	P06
4.3	Straight pipe section	P07
5	Electric description	P08
5.1	After the start of the display instrument	P08
5.2	Display interface	P08
5.3	Power supply fuse replacement	P09
6	Panel description	P09
6.1.	Panel structure and key definition	P09
6.2	Function description	P09
7	Wiring	P10
7.1	Description of terminal	P10
7.2	Current output	P11
7.3	Pulse output	P12
7.4	instrument of communication function	P12
8	menu construction	P13
9	detail parameter instructions	P14

1. brief introduction of turbine flowmeter.

KF500 type turbine flow meter is a speed type flow meter. For the measurement of full closed pipeline, a continuous flow of liquid volume flow. Turbine flow sensor for measurement of low viscosity liquid, has high precision, can withstand the working pressure and other characteristics. Pre-amplifier differential pulse output, 4~20mA standard current signal output type, ordinary type flow detector, wear resistant and anticorrosive, which wear resistant except the bearing and the shaft made of hard alloy (25mm caliber following bearings with Hong Gangyu), and the design of pair of impeller with appropriate reverse thrust, which is more suitable for measuring gasoline lubricants the poor performance of liquid.



2. Turbine flow sensor

1.1 Flow range

DN(mm)	Flow range (GPM)		Pressure (MPa)	Maximum pressure Loss(MPa)	Ambient temperature (°C)
	accuracy 0.5%	accuracy 1.0%			
2*	/	0.045~0.6	1.6	0.12	-25~55
3*	/	0.18~1.2			
4*	/	0.18~1.2			
6*	0.45~2.6	0.45~2.6	6.3	0.08	
10	1.1~5.2	1~5.2	16*	0.05	
15	2.6~18	1.8~18	25	0.035	
20	4.8~30	3~30	40*		
25	7~45	4.5~45	2.5		
32	11~70	7~70	2.5	0.03	
40	13~88	11~110	1.6 or 2.5	0.025	
50	18~180	18~180			
65	26~260	26~260			
80	45~450	45~450	1.6	0.025	
100	90~700	70~700	1.6		
150	220~1320	180~1800			
200	450~2640	350~3500			

Note : *Special orders

1.2 Flange connection dimension

DN		D1	D2	nxøA	L	Weight (kg)
10	3/8"	90	60	4x14	60	1.9
15	1/2"	95	65	4x14	75	2.0
20	3/4"	105	75	4x14	75	2.9
25	1"	115	85	4x14	100	3.7
32	1¼"	140	100	4x18	120	5
40	1½"	150	110	4x18	140	7
50	2"	165	125	4x18	150	9
65	2½"	185	145	4x18	180	11
80	3"	200	160	8x18	200	14
100	4"	220	180	8x18	220	21
150	6"	285	240	8x22	300	36
200	8"	340	295	12x22	360	57

Note: the above table to a national standard flange connection dimension, other standard please contact with manufacturer

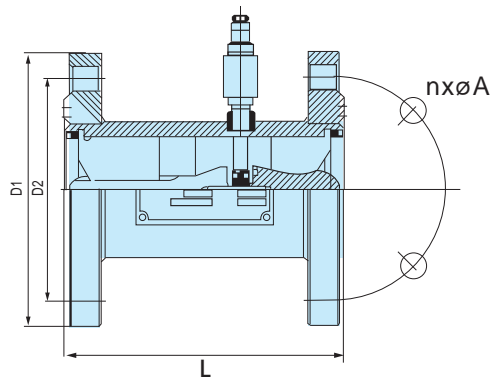

1.3 size of thread screw

DN	2*, 3*, 4*			6	10	15	20	25	32
G	1/4			3/8	1/2	1	1	1¼	1½
L ₁ mm	7			11	16	18	18	23	25
Lmm	40	55	40	50	60	75	75	100	120
weights (KG)	0.5	0.7	0.5	0.6	0.65	1.0	1.2	1.7	2.2

"*" special order

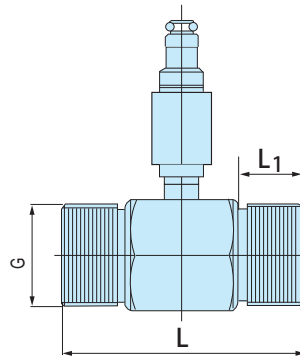

1.4 Hoop - type connection size

DN		G	L	Weight (kg)
10	3/8"	51	100	1.9
15	1/2"	51	100	2.0
20	3/4"	51	100	2.9
25	1"	51	100	3.7
32	1 1/4"	64	140	5
40	1 1/2"	64	140	7
50	2"	77.5	150	9
65	2 1/2"	91	182	11

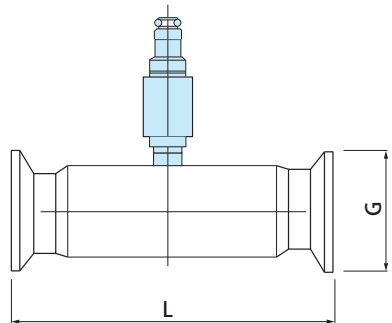

3 Selection

KF500-

DN	2	2mm(G3/8")
	3	3mm(G3/8")
	4	4mm(G3/8")
	6	6mm(G3/8")
	10	10mm(G3/8")
	15	15mm(G1")
	20	20mm(G1")
	25	25mm(G1¼")
	32	32mm(G1½")
	40	40mm(G1½")
	50	50mm(G2")
	65	60mm
	80	80mm
	100	100mm)
	150	150mm
200	200mm	
Medium	Y	Liquid
	Q	Gas
Output	P	pulse output type
	C	Current output type
	D	24VDC power supply with cumulative, current, pul
	V	220VAC power supply with cumulative, current, pul
	B	Battery powered accumulation without out
Connection mode	F	Flange connection
	L	Thread connection
	K	Hoop - type connection
Pressure	P1		PN1.6MPa
	P2		PN2.5MPa
	P3		PN4.0MPa
	P4		PN6.3

4 Installation

4.1 the installation site

- ◆ The environment temperature is $-25 \sim +55 \text{ }^{\circ}\text{C}$, humidity $< 80\%$, prevent the rain
- ◆ Ventilation is good, avoid the corrosive liquid and the gas contact
- ◆ Mechanical vibration, collision avoidance
- ◆ shell must be grounded to prevent electrical and radio interference, away from the strong magnetic and frequency conversion device
- ◆ Mounting position should be considered to facilitate the installation, commissioning and maintenance

4.2 Installation direction and position

In order to ensure the measurement precision of turbine flow meter, flow meter should be installed horizontally on the pipeline, at the same time attention to flow direction and flow arrow aligned. If the vertical installation, must ensure that the medium flows from down to up, ensure pipe is filled with medium

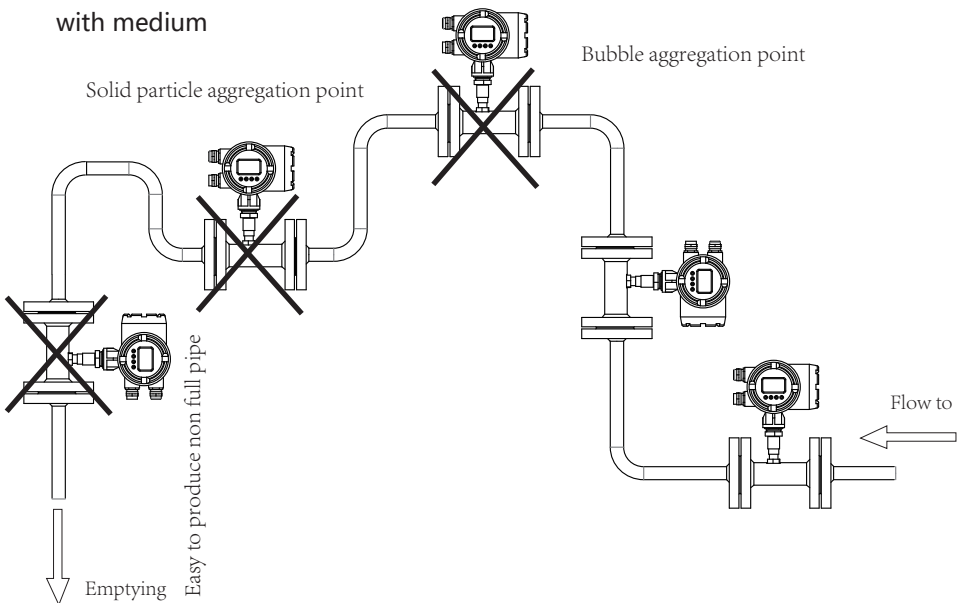

4.3 Straight pipe section

General upstream pipe section not less than $15D$, the downstream tube section not less than $5D$ (D flow path)

Concentric reducer

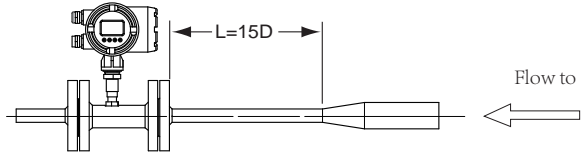

45 degree elbow

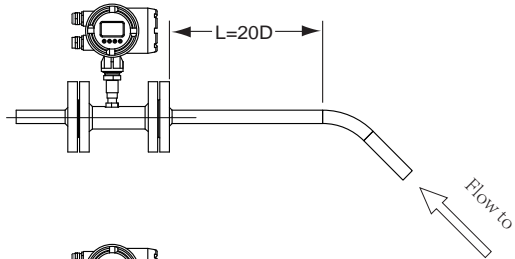

Continuous bend

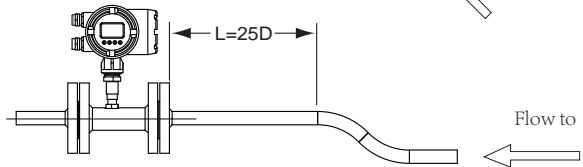

90 degree elbow

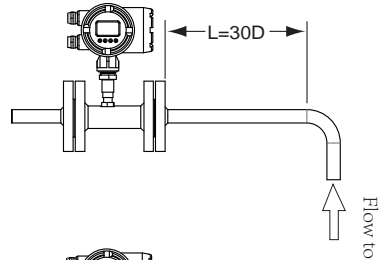

The pipeline has Valve

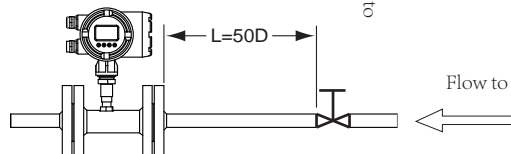

5 Electric description



The instrument is energized before, please check the sensor installation instructions to verify the system is properly installed and connected. Sent to the user 's meter includes a sensor and the signal converter in two parts, all the data has been based on the user's requirements and the company's technical specifications in the manufacturing process is set to direct operation of the.

5.1 After the start of the display instrument

At the completion of instrumentation electrical connections thereto and confirmation, the electricity to flow meter. Instrument power converter to perform initialization, display the logo of the company (see below). Wait for 3 seconds after the instrument automatically enter the measurement mode, immediately began to flow measurement and display the current flow measurements or other self diagnostic information.

If the instrument in power without any display (display no backlight), in recognition of power supply and connection mode to meet the requirements, can view the instrument power fuse is intact.

5.2 Display interface

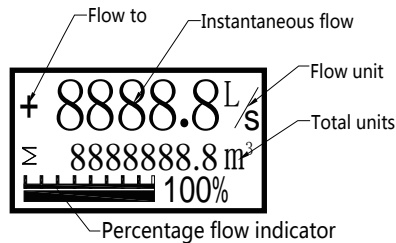

Flow display interface

1. The first row shows the instantaneous flow and flow unit;
2. Second rows show the cumulative total and total units;
3. Third line displays the current flow relative to the maximum flow rate and the percentage ;

5.3 Power supply fuse replacement



Fuse replacement should have certain professional ability of the personnel to perform! If the instrument in the replacement fuse still did not show, please contact with the manufacturers.

Operation steps:

1. Instrument power after open instrument wiring part cover:
 2. Remove fuse **FUSE** cover, remove the fuse ;
 3. With the same specifications of the fuse replacement ;
 4. Recovery of converter exit sealed state, instrumentation and power on again.
- Fuse specification: 220VAC power supply fuse specification: 500mA/250V; 24VDC power supply fuse specification: 500mA/250V

6 Panel description

6.1. Panel structure and key definition

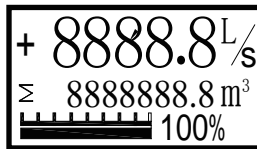

6.2 Function description

Set parameters confirmation and exit sub menu key (◀)

▼ Setting " down " and " decline " (data variable key down key)

▶ Setting " right " key (shift right key), to enter and cancel

▲ " Set up " and " incremental " data variable keys (up ")

Shortcut keys and key combinations

◀ and ▲ Reducing the contrast of the display

◀ and ▼ increase the contrast of the display

7 Wiring

7.1. Description of terminal

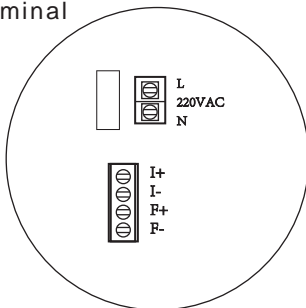

NO	Mark	Function description	Note
1	I+	4-20mA Positive	Load resistance $\leq 500 \Omega$ (including cable)
2	I-	4-20mA Negative	
3	F+	Pulse Positive	Passive output mode The output amplitude of the load current is less than or equal to 50mA 24V;
4	F-	Pulse Negative	
5	L	220V	
6	N		

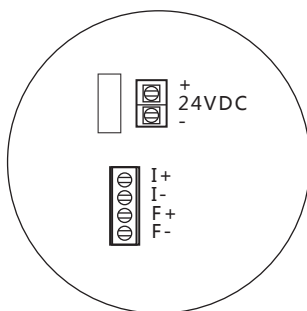

NO	Mark	Function description	Note
1	I+	4-20mA Positive	Load resistance $\leq 500 \Omega$ (including cable)
2	I-	4-20mA Negative	
3	F+	Pulse Positive	Passive output mode The output amplitude of the load current is less than or equal to 50mA 24V;
4	F-	Pulse Negative	
5	24VDC +		Pay attention to the power supply voltage
6	24VDC -		

7.2 Current output

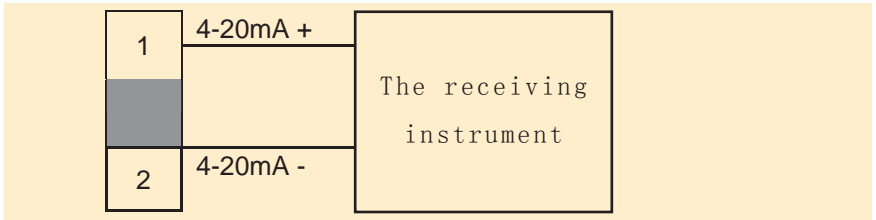

Maximum flow

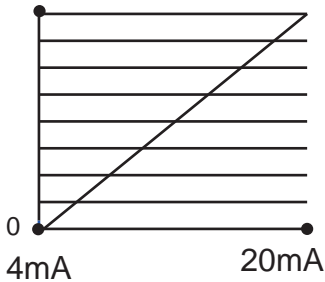

The flow transmitter output current has to realize the electrical isolation, output to the active mode. Current output mode for 4-20mA, 20mA current output corresponding to the flow rate value by the parameter " scale flow value " the decision (see instrument factory brand measuring range value). Current output the maximum allowable load resistance of 750 ohm, the load resistor includes the use of cables connected to the resistance. Current output lines connected to recommend the use of VVP2x16/0.15 PVC insulation shielded PVC sheath wire.

2.Current calibration

4mA Current calibration

When the instrument of instantaneous flow rate and a two meter display the instantaneous flow is not consistent in out parameter setting under the premise, remove the two meter line with an ammeter is connected to two terminals. Press the right arrow key instrument display menu, select instrument calibration, enter the 4mA calibration. If the current table display 4mA, it does not require calibration of current. If not 4mA on the instrument input current meter current.

20mA Current calibration

When the instrument of instantaneous flow rate and a two meter display the instantaneous flow is not consistent in out parameter setting under the premise, remove the two meter line with an ammeter is connected to two terminals. Press the right arrow key instrument display menu, select instrument calibration, enter the 20mA calibration. If the current table display 20mA, it does not require calibration of current. If not 2mA on the instrument input current meter current.

7.3 Pulse output

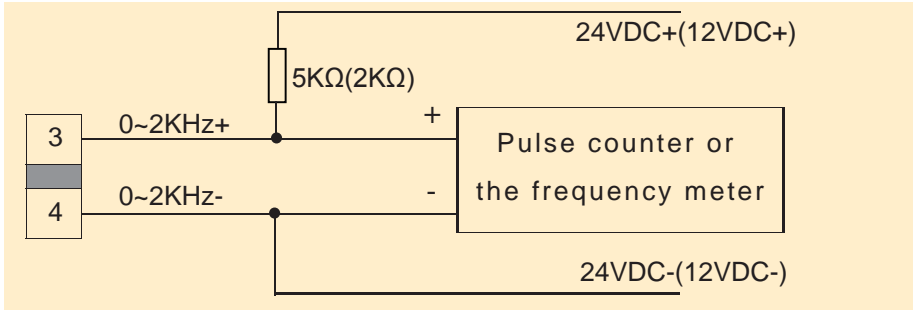

The converter frequency, pulse output has to realize the electrical isolation, the output for the passive mode (see above).

Converter frequency, pulse output by a transistor output. Max output pulse frequency is 5KHZ, output pulse amplitude 24V. Maximum load current 0.2A.

Due to the frequency and pulse width of the output terminals are common, so cannot be selected at the same time two output modes. The user can pass on the parameters of " frequency " settings to select the mode of operation.

1. frequency output

Set pulse equivalent value of zero, open instrument frequency output function, corresponding to the upper frequency limit of maximum flow instrument or instrument menu in the " scale flow ". Detailed setup procedures . See Synonyms at upper frequency limit set

2. equivalent output

Set instrument menu " pulse equivalent L/P " is not zero opened instrument equivalent output function. Pulse output by the parameters of equivalent " pulse equivalent to L/P". Detailed setup procedures . See Synonyms at pulse equivalent set

7.4 instrument of communication function

This system with RS485, MODBUS ASC converter, MODBUS RTU communication function (requiring the user to specify when ordering). Through the " 485 output communication protocol " parameter settings to specify. The instrument of communication interface to the specific technical instructions is dedicated to provide the " protocol " .

8 menu construction

Mode of Measuree press ▶	Configuration Menu press ▶	Parameter item Press ▶	Secondary Parameter item		
	1. BASIC	1.1 PV Units			
		1.2 PV Decimal			
		1.3 Total Units			
		1.4 Total Decimal			
		1.5 Damping(s) (0.1~99.9)			
	2. SYSTEM	2.1 New Password			
		2.2 Language			
		2.2 Signal		2.2.1 Qmax(m3/h) 2.2.2 Low Cutoff%	
		2.3 Pulse Output		2.3.1 Freq Direct 2.3.2 Freq Max(Hz) 2.3.3 Liter/Pulse 2.3.4 Pulse Width(ms) 2.3.5 Pulse Level	
			2.4 RS485 Output		2.4.1 RS485 Ptotocol 2.4.2 Baudrate 2.4.3 Data Bit 2.4.4 Parity 2.4.5 Stop Bit 2.4.6 Dev Address
				2.5 Total Set	2.5.1 Clear Total 2.5.2 FWD preset(m3)
				2.6 Load Settings	
				3. CALIBRATION	3.1 4mA Trim
		3.2 20mA Trim			
		4. TEST		4.1 Loop Test	
	4.2 Pulse Test				

Mode of Measuree Press	Configuration Menu press ◀	Parameter item Press ◀	Secondary Parameter item Press ◀
---------------------------	-------------------------------	---------------------------	--

9 detail parameter instructions

parameter item	parameter setting range	instructions
PV Units	L/S, L/m, L/h, m3/S, m3/m, m3/h, G/S, G/m, G/h	S=second,M=minute, H=hour,L=liter, M3=cubic meter,G=gallon
Total units	L, m3,G	
PV Decimal	1, 2, 3	set the instantaneous flow of decimal places displayed
Total Decimal	1, 2, 3	set the totalizer flow of decimal places displayed
language	chinese, english	
Qmax(m3/h)	0.0001-99999999	unit: m3/h
tLow cutoff %	0.0-9.9	this parameter can move small flow display,the percentage for the full range
Freq Max(HZ)	100.0-5000.0Hz	maximum frequency output,it's effectual when pulse equivalent is ZERO
Liter/Pulse	larger than system's minimum is ok	one pulse on behalf of how many liters
pulse width	0.0-1000.0ms	do not need under normal condition
pulse level	low effective ,high effective	clear total accumulation
clear Total	No, Yes	
FWD preset(m3)		If replace instrument,can input previous totalizer flow,continue to accumulation
4mA Trim	3.000-5.000	calibrate output signal without flow.
20mA Trim	19.000-21.000	calibrate output signal of full range